

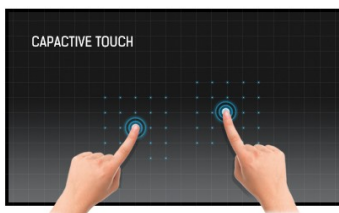

27" 10 point multi-touch monitor with Edge to Edge glass and webcam

With 1920x1080 Full HD resolution and Projective Capacitive 10 point touch technology, the ProLite T2735MSC delivers seamless and accurate touch response. Featuring AMVA+ LED-backlit LCD screen technology, it offers exceptional colour performance and wide viewing angles, making it an excellent choice for a vast array of demanding interactive applications. Users can benefit from its hinged stand allowing the monitor to lay down completely flat for use as a giant tablet. The T2735MSC comes equipped with several video inputs and a USB 3.0 HUB as well as stereo speakers delivering good quality sound. An ideal screen for Interactive Digital Signage, InStore Retail, Gaming and Interactive Presentations purposes.



TOUCH TECHNOLOGY - CAPACITIVE

This technology uses a sensor-grid of micro-fine wires integrated into the glass that covers the screen. Touch is detected because electrical characteristics of the sensor grid change when human finger is placed on the glass. Thanks to the glass overlay this technology is highly durable, and the touch function remains unaffected even if the glass is scratched. It offers perfect picture performance and will work with human finger (also latex gloved) and stylus-pen.



AMVA+

AMVA+ Panel technology offers 24 bit 'True Colour' performance and amazing viewing angles.

1. DISPLAY CHARACTERISTICS

ASPECT RATIO	16 : 9
PANEL	AMVA+ LED-backlit
NATIVE RESOLUTION	Full HD 1080p, 1920 x 1080 (2.1 megapixel)
BRIGHTNESS	260 cd/m ² with touch panel
ADVANCED CONTRAST	5 000 000 : 1 ACR
STATIC CONTRAST	3 000 : 1 with touch panel
RESPONSE TIME	5ms
VIEWING ZONE	horizontal/vertical: 178° / 178° ; right/left: 89° / 89° ; up/down: 89° / 89°
DISPLAY COLOUR	16.7 million
TOUCHTECHNOLOGY	projective capacitive, multitouch (10 compatible touch points - HID, only with supported OS), activated by finger
GLASS HARDNESS	7H minimum
LIGHT TRANSMITTANCE	87%
DISPLAY AREA H X W	336.15 x 597.6 mm; 13.2" x 23.5"
PIXEL PITCH H X V	0.311 x 0.311 mm
HORIZONTAL SYNC	24 - 80kHz
VERTICAL SYNC	55 - 75Hz
SYNCHRONIZATION	Separate Sync

2. INTERFACES / CONNECTORS / CONTROLLERS

ANALOG INPUT CONNECTOR	VGA
DIGITAL INPUT CONNECTOR	DVI-D, HDMI (MHL)
HEADPHONE CONNECTOR	yes
USB HUB	UP 1 x USB 3.0 / DOWN 2 x USB 3.0
OTHER	USB (for touch connectivity), USB 3.0

3. FEATURES

PLUG & PLAY	VESA DDC2B™
CONTROLS	On-Screen-Display in 9 languages (EN, FR, DE, NL, PL, RU, JP, Chinese - traditional and simplified) and 5 front controls (Power, Select/ Input select, Scroll up/ Audio Adjust, Scroll down/ i-Style Colour, Menu)
SPEAKERS	2 x 2 W (Stereo)
ANTI-THEFT-DEVICE	Kensington-lock™ prepared
REGULATIONS	CE, TÜV-Bauart, VCCI-B, PSE, CU
TILT ANGLE	15-70° up; ° down
VESA MOUNTING	100 x 100 mm
COLOUR	Black
OTHER	integrated webcam and microphone

4. ACCESSORIES

DRIVER	multi-touch: Windows7/8 (HID compliant), single-touch: Vista, XP, 9X, 2000, CE, NT4, Linux
INCLUDED ACCESSORIES	power cable, DVI-D signal cable, MHL cable, Audio cable, USB cable, quick start guide, safety guide

5. POWER MANAGEMENT

POWER SUPPLY	AC 100 - 240 V, 50 / 60 Hz
POWER SUPPLY UNIT	internal
POWER USAGE	36 W typical; max. 0.5 W in Power management mode
POWER MANAGEMENT	VESA DPMS

6. EU ENERGY EFFICIENCY LABEL

ENERGY EFFICIENCY CLASS	B
ON MODE POWER CONSUMPTION	37.4W
ANNUAL ENERGY CONSUMPTION	55 kWh/annum*
VISIBLE SCREEN DIAGONAL	69 cm; 27"; (27" segment)

This is information under Regulation (EU) No 1062/2010.

**Based on the power consumption of the television operating 4 hours per day for 365 days. The actual energy consumption will depend on how the television is used.*

7. EPEAT SILVER

EPEAT	EPEAT is a comprehensive environmental rating that helps identify greener computers and other electronic equipment. The Silver certification means the monitor meets all required criteria plus at least 50% of the optional requirements. EPEAT Silver is valid in countries where iiyama registers the product. Please visit www.epeat.net for the registration status in your country.
-------	--

8. DIMENSIONS / WEIGHT

DIMENSIONS W X H X D	672.5 x 419 x 50 mm
WEIGHT	8.3 kg

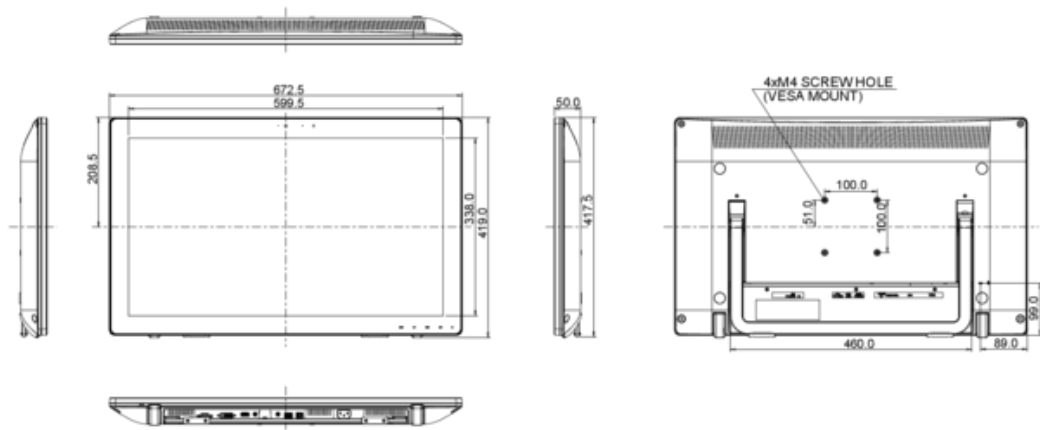

All trademarks and registered trademarks acknowledged. E & O E. Specification subject to change without notice. All LCD's comply with ISO-9241-307:2008 in connection with pixel defects.

© IIYAMA CORPORATION (). ALL RIGHTS RESERVED.